

**RECTANGULAR DISSIPATIVE SILENCER**  
BROADBAND • LOW INSERTION LOSS  
TAPERED POD DESIGN  
**MODEL: RBB-LP**

**SPECIFICATIONS:**

Engineered Acoustics' dissipative, rectangular duct silencers are designed to offer superior acoustic and aerodynamic performance. Constructed with a standard outer casing of 22 gauge (0.85) galvanized steel. Each internal "pod" includes a solid 22 gauge (0.85) elliptical nosepiece, 22 gauge (0.85) acoustically transparent perforated metal, and is exponentially tapered to minimize dynamic pressure loss and maximize static pressure regain. The inorganic, odorless, vermin and moisture proof, absorption media is compressed a minimum of 5% to eliminate voids and prevent settling.

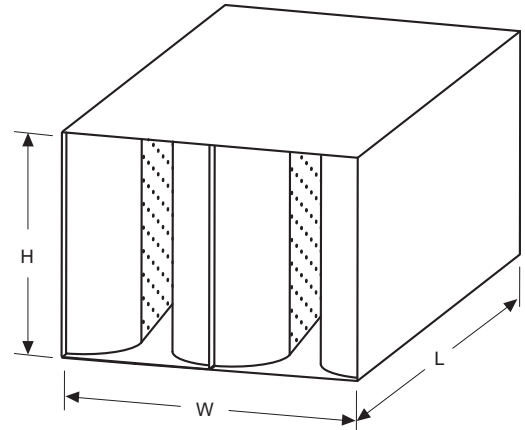

**INSERTION LOSS IN DECIBELS WITH AND WITHOUT AIRFLOW (+) FORWARD FLOW (-) REVERSE FLOW**

LENGTH (inches)	FACE VELOCITY (fpm)	STATIC PRESSURE DROP (in. w.g.)	OCTAVE BAND / CENTER FREQUENCY (Hz)							
			1	2	3	4	5	6	7	8
			63	125	250	500	1000	2000	4000	8000
36	-2000	.20	1	5	10	18	25	19	13	9
	-1000	.07	1	5	9	19	25	19	13	10
	0	0	2	4	9	18	25	19	14	10
	+2000	.19	2	4	8	16	24	19	15	10
	+2500	.30	1	4	8	16	24	19	15	10
60	-2000	.30	1	9	15	31	41	30	17	8
	-1000	.10	2	9	14	31	42	31	17	9
	0	0	2	7	13	30	45	33	19	12
	+2000	.27	2	6	12	27	42	34	21	12
	+2500	.42	1	6	12	26	41	33	20	12
84	-2000	.40	4	13	23	40	44	38	21	11
	-1000	.12	4	11	20	42	47	40	23	11
	0	0	4	10	19	41	49	42	26	15
	+1000	.10	3	9	18	40	49	42	27	15
	+2000	.38	3	9	17	39	47	40	27	16

**NOTE:**

- The incombustible filler material does not exceed the following fire hazard classifications when tested in accordance with NFPA 90 and UL 181: Flame spread 25, Fuel contributed 0, Smoke development 50.
- All performance data is independently tested using a 24" x 24" (610 x 610) rectangular sample. Forward Flow (+) occurs when noise and air travel in the same direction. Reverse Flow (-) occurs when noise and air travel in opposite directions.
- Face velocities represent velocity across the total inlet area of the silencer. Static pressure drop is reported in accordance with standard ASTM E-477 involving specified lengths of straight duct before and after the test specimen. Actual system conditions may vary from the standard and require additional system performance calculations.

**SELF GENERATED NOISE**

FACE VELOCITY (fpm)	OCTAVE BAND / CENTER FREQUENCY (Hz)							
	1	2	3	4	5	6	7	8
	63	125	250	500	1000	2000	4000	8000
-2000	66	61	57	61	63	67	59	52
-1000	55	51	48	52	56	49	42	32
+1000	58	49	40	39	34	27	24	22
+2000	62	59	52	50	51	54	53	48

**FACE AREA CORRECTION FACTORS**

FACE AREA (sq. ft.)	.5	1	2	4	8	16	32	64	128	256
PWL CORRECTION FACTOR (dB)	-8	-6	-3	0	+3	+6	+9	+12	+15	+18

**OPTIONS:**

- High temperature sealant
- Field or factory assembled multiple modules
- TDF Flange one or both ends
- 1.5" (38) flange one or both ends
- 18 gauge (1.31) outer casing construction

Dimensions are in inches (mm's).

<b>SCHEDULE TYPE:</b>				
<b>PROJECT:</b>				
<b>ENGINEER:</b>		<b>DATE</b>	<b>B SERIES</b>	<b>SUPERSEDES</b>
<b>CONTRACTOR:</b>		4 - 2 - 08	RBB	1 - 13 - 06
				<b>DRAWING NO.</b>
				RBB-LP