

CIRCULAR DISSIPATIVE SILENCER
BROADBAND • HIGH INSERTION LOSS
TAPERED POD DESIGN
MODEL: CBB-LP

SPECIFICATIONS:

Engineered Acoustics' dissipative, circular duct silencers are designed to offer superior acoustic and aerodynamic performance. Constructed with a standard outer casing of 22 gauge (0.85) galvanized steel, all external seams are lock formed and sealed to withstand up to 10" w.g. (2.5 kPa) pressure differential. Each internal "pod" includes a solid 22 gauge (0.85) elliptical nosepiece, 22 gauge (0.85) acoustically transparent perforated metal, and is exponentially tapered to minimize dynamic pressure loss and maximize static pressure regain. The inorganic, odorless, vermin and moisture proof, absorption media is compressed a minimum of 5% to eliminate voids and prevent settling.

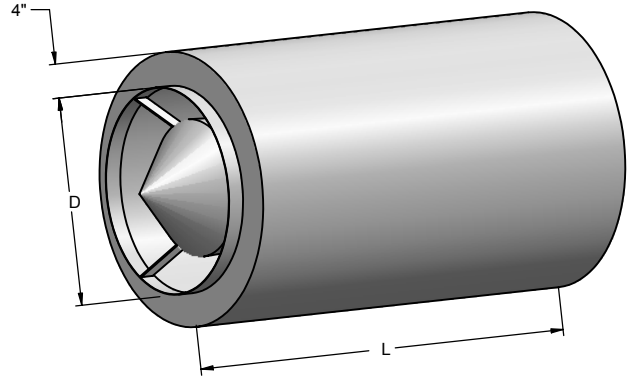

INSERTION LOSS IN DECIBELS WITH AND WITHOUT AIRFLOW (+) FORWARD FLOW (-) REVERSE FLOW

NOTES:

- The incombustible filler material does not exceed the following fire hazard classifications when tested in accordance with NFPA 90A and UL181: Flame spread 25, Fuel contributed 0, Smoke development 50.
- Forward Flow (+) occurs when noise and air travel in the same direction. Reverse Flow (-) occurs when noise and air travel in opposite directions.
- Face velocities represent velocity across the total inlet area of the silencer. Static pressure drop is reported in accordance with standard ASTM E-477 involving specified lengths of straight duct before and after the test specimen. Actual system conditions may vary from the standard and require additional system performance calculations.

SELF GENERATED NOISE

FACE VELOCITY (fpm)	OCTAVE BAND / CENTER FREQUENCY (Hz)							
	1	2	3	4	5	6	7	8
	63	125	250	500	1000	2000	4000	8000
	AIRFLOW GENERATED SOUND POWER LEVELS (dB)							
-1500	59	52	44	43	45	47	44	42
-1000	54	47	39	38	40	42	39	37
+1000	53	46	39	37	37	39	37	35
+1500	58	51	44	42	44	42	42	40

FACE AREA CORRECTION FACTORS

FACE AREA (sq. ft.)	1.5	3	6	12	24	48
PWL CORRECTION FACTOR (dB)	-3	0	+3	+6	+9	+12

Connection Size (inches)	Length (inches)	Face Velocity (fpm)	Static pressure drop (in. w.g.)	OCTAVE BAND / CENTER FREQUENCY (Hz)							
				1	2	3	4	5	6	7	8
				63	125	250	500	1000	2000	4000	8000
INSERTION LOSS (dB)											
12	24	-1500	0.22	4	7	16	28	39	44	43	31
		-750	0.06	4	7	15	27	38	43	43	31
		0	0.00	4	7	15	27	37	43	43	31
		750	0.05	4	7	14	26	36	42	43	31
		1500	0.20	4	7	13	25	35	41	43	31
	36	-1500	0.36	5	10	23	41	57	60	60	46
		-750	0.09	5	10	22	40	56	60	60	46
		0	0.00	5	10	22	40	55	60	60	46
		750	0.08	5	10	21	39	54	60	60	46
		1500	0.33	5	10	20	38	53	60	60	46
24	48	-1500	0.21	4	8	22	34	47	47	35	20
		-750	0.05	4	8	21	33	46	46	35	20
		0	0.00	4	8	21	33	45	46	35	20
		750	0.05	4	8	20	32	44	45	35	20
		1500	0.19	4	8	19	31	43	44	35	20
	72	-1500	0.32	6	12	33	49	60	60	49	29
		-750	0.08	6	12	32	48	60	59	49	29
		0	0.00	6	12	32	48	60	59	49	29
		750	0.07	6	12	31	47	59	58	49	29
		1500	0.29	6	12	30	46	58	57	49	29
36	72	-1500	0.22	6	11	26	41	47	39	24	15
		-750	0.06	6	11	25	40	46	38	24	15
		0	0.00	6	11	25	40	45	38	24	15
		750	0.05	6	11	24	39	44	37	24	15
		1500	0.20	6	11	23	28	43	36	24	15
	108	-1500	0.30	8	16	38	58	60	56	36	23
		-750	0.08	8	16	37	57	60	55	36	23
		0	0.00	8	16	37	56	60	55	36	23
		750	0.07	8	16	36	56	59	54	36	23
		1500	0.27	8	16	35	55	58	53	36	23
48	96	-1500	0.21	7	14	31	45	45	34	19	14
		-750	0.05	7	14	30	44	44	33	19	14
		0	0.00	7	14	30	44	43	33	19	14
		750	0.05	7	14	29	43	42	32	19	14
		1500	0.19	7	14	28	42	41	31	19	14
	144	-1500	0.26	11	21	46	60	60	50	29	21
		-750	0.06	11	21	45	59	59	49	29	21
		0	0.00	11	21	45	59	59	49	29	21
		750	0.06	11	21	44	58	57	48	29	21
		1500	0.23	11	21	43	57	56	47	29	21

OPTIONS:

- High temperature Sealant.
- Field or Factory assembled multiple modules.
- TDF Flange one or both ends.
- 1.5" flange one or both ends
- 18 gauge (1.31mm) outer casing construction.

SCHEDULE TYPE:

PROJECT:

ENGINEER:

CONTRACTOR:

Dimensions are in inches (mm).

DATE	B SERIES	SUPERSEDES	DRAWING NO.
5-09-06	CBB	01-19-06	CBB-LP